

January 3,2020

## AGENDA

TO: Members of the Lake/Airport Committee and the Water/Environmental Committee

Lake/Airport Committee

Shawn Burtle  
Larry Budd  
Chris Skultety

Water/Environmental Committee

Ernie Dorchinecz  
Larry Budd  
Chris Skultety

There will be a meeting of the Lake/Airport Committee and the Water/Environmental Committee on Thursday, January, 9, 2020 starting at 6:00 P.M. **at the Water Treatment Facility**. 2021 Lincoln Trail, Taylorville, Illinois.

The Purpose of the Lake/Airport Committee Meeting, which begins at 6:00 P. M., is for discussion and consideration in whole or in part of the following subject matters and/or motions to approve/deny/reject/review/table/amend:

1. Purchase M4000 Card Reader for Gas Pumps at the Airport
  2. Establish the Airport Fund as an Enterprise Fund
  3. Airport Manager's Report
  4. New Boat Dock Request
  5. Revenue for Dredging the Lake
  6. Cabin Maintenance
  7. Install New Keyless Entry on Cabins
  8. Review Cabin Rental Deposit Amount
  9. Tent Camping
  10. Application Form for Building Boat Docks and Ski Lifts
  11. Two (2) Campers on Lake Lots
  12. Lake Patrol
  13. Asian Carp
  14. Lake Superintendent's Report
  15. Any Other Matters Which May Properly Come Before This Committee
- Per subparagraph (g) of 5 ILCS 120/2.06, this portion of the Lake/Airport Committee Meeting is reserved for any person wishing to address the Committee on any relevant subject matters concerning the City. The Illinois Open Meetings Act (5 ILCS 120/1 et seq.) mandates NO action shall be taken on subject matters not listed on the agenda, but the Committee may direct staff to address the topic or refer the subject matter to a future Council and/or Committee Meeting. If anyone wishes to address the Committee, please provide your name and address, limit your comments or presentation to three (3) minutes, and avoid repetitious comments. Thank you.
16. Adjournment

The Purpose of the Water/Environmental Committee Meeting, which will immediately follow the Lake/Airport Committee Meeting, is for discussion and consideration in whole or in part of the following subject matters and/or motions to approve/deny/reject/review/table/amend:

1. Monthly Status Report
  2. Benton & Associates Project Update
  3. Partial Pay Request from Plocher Construction
  4. Invoices from Benton & Associates, Clark-Dietz & Dickinson Hussman
  5. Alum Pump Purchase
  6. Water Collection Office Update
  7. Water Superintendent Updates
  8. Any Other Matters Which May Properly Come Before This Committee
- Per subparagraph (g) of 5 ILCS 120/2.06, this portion of the Water/Environmental Committee Meeting is reserved for any person wishing to address the Committee on any relevant subject matters concerning the City. The Illinois Open Meetings Act (5 ILCS 120/1 et seq.) mandates NO action shall be taken on subject matters not listed on the agenda, but the Committee may direct staff to address the topic or refer the subject matter to a future Council and/or Committee Meeting. If anyone wishes to address the Committee, please provide your name and address, limit your comments or presentation to three (3) minutes, and avoid repetitious comments. Thank you.

9. Adjournment

Your attendance will be appreciated.

Ernie Dorchinecz, Chairman  
Lake/Airport Committee

Shawn Burtle, Chairman  
Water/Environmental Committee

ED/SB: ss

cc: Mayor Barry  
City Attorney  
All Other Aldermen  
Jacque Nation  
Bill Newberry  
Bart Bialas  
David Speagle  
All Other Superintendents  
Joe Greene  
Kellie Hamell

Breeze Courier  
State Journal Register  
WCFN  
WTIM  
Herald & Review  
WAND  
Chamber of Commerce  
Nick Hackney  
Benton & Associates  
Alan Mills  
Bill Jones  
Brandis Aircraft  
Dave Copenbarger

February 7, 2020

## AGENDA

TO: Members of the Water/Environmental Committee, Lake/Airport Committee

### Water Committee

Ernie Dorchinecz

Larry Budd

Chris Skultety

### Lake /Airport Committee

Shawn Burtle

Larry Budd

Chris Skultety

There will be a meeting of the Water/Environmental Committee and Lake/Airport Committee on Thursday, February 13, 2020 at 6:00 P.M. in the Council Chambers of the Municipal Building, 115 North Main, Taylorville, Illinois.

The purpose of the Water/Environmental Committee Meeting, which begins at 6:00 P.M., is for discussion and consideration in whole or in part of the following subject matters and/or motions to approve/deny/reject/review/table/amend:

1. Monthly Status Report
2. Water Collection Office Update
3. Water Superintendent's Report
4. Any Other Matters Which May Properly Come Before This Committee

Per Public Act 96-1473 this portion of the Water/Environmental Committee Meeting is reserved for any person wishing to address the Committee on issues that are relevant to that Committee. The Illinois Open Meetings Act (5 ILCS 120/1) mandates NO action shall be taken on matters not listed on this agenda, but the Committee may direct staff to address the topic or refer the matter to a future Water/Environmental Committee Meeting or a different Committee. Please provide the Committee with your name & address; try to limit presentation to three (3) minutes; and avoid repetitious comments. Thank you.

### 5. Adjournment

The purpose of the Lake/Airport Committee Meeting, which will immediately follow the Water/Environmental Committee Meeting is for discussion and consideration in whole or in part of the following subject matters and/or motions to approve/deny/reject/review/table/amend:

1. Length of Boat Docks
2. Applications for New Boat Docks
3. Tent Camping Charges
4. Revenue for Dredging the Lake
5. Cabins-Maintenance Needs
6. New Keyless Entry on Cabins

7. Lake Superintendents Report
8. M4000 Card Reader
9. QT Pod Service Agreement
10. Enterprise Funds
11. Airport Manager's Report
12. Any Other Matters Which May Properly Come Before This Committee

Per Public Act 96-1473 this portion of the Lake/Airport Committee Meeting is reserved for any person wishing to address the Committee on issues that are relevant to that Committee. The Illinois Open Meetings Act (5 ILCS 120/1) mandates NO action shall be taken on matters not listed on this agenda, but the Committee may direct staff to address the topic or refer the matter to a future Lake/Airport Committee Meeting or a different Committee. Please provide the Committee with your name & address; try to limit presentation to three (3) minutes; and avoid repetitious comments. Thank you.

13. Adjournment

Your attendance will be appreciated.

Shawn Burtle, Chairman  
Water/ Environmental Committee

Ernie Dorchinecz, Chairman  
Lake/Airport Committee

SB/ED: ss

cc: Mayor Barry  
City Attorney  
All Other Aldermen  
City Treasurer  
David Speagle  
Bart Bialas  
All Other Superintendents  
Bill Newberry  
Joe Greene  
Kellie Hamell

Breeze Courier  
State Journal Register  
WCFN  
WTIM  
Herald & Review  
WAND  
Chamber of Commerce  
Nick Hackney  
Benton & Associates  
Alan Mills  
Bill Jones  
Brandis Aircraft  
Dave Copenbarger

February 6, 2020

## AGENDA

TO: Members of the Lake/Airport Committee and the Water/Environmental Committee

Lake/Airport Committee

Shawn Burtle

Larry Budd

Chris Skultety

Water/Environmental Committee

Ernie Dorchinecz

Larry Budd

Chris Skultety

There will be a meeting of the Lake/Airport Committee and the Water/Environmental Committee on Thursday, March 12, 2020 starting at 6:00 P.M. in the Council Chambers of the Municipal Building, 115 North Main Taylorville, Illinois.

The Purpose of the Lake/Airport Committee Meeting, which begins at 6:00 P. M., is for discussion and consideration in whole or in part of the following subject matters and/or motions to approve/deny/reject/review/table/amend:

1. Airport Manager's Report
  2. Review Ordinance 7-4-6 (C.1) Regarding Length of Boat Docks
  3. Cabins-Maintenance Needs
  4. Revenue for Dredging the Lake
  5. Tent Camping-Location
  6. Card Reader Maintenance Agreement
  7. Two (2) Campers on One Lake Lot
  8. FY 2020/2021 Lake Budget
  9. Lake Superintendent's Report
  10. Any Other Matters Which May Properly Come Before This Committee
- Per subparagraph (g) of 5 ILCS 120/2.06, this portion of the Lake/Airport Committee Meeting is reserved for any person wishing to address the Committee on any relevant subject matters concerning the City. The Illinois Open Meetings Act (5 ILCS 120/1 et seq.) mandates NO action shall be taken on subject matters not listed on the agenda, but the Committee may direct staff to address the topic or refer the subject matter to a future Council and/or Committee Meeting. If anyone wishes to address the Committee, please provide your name and address, limit your comments or presentation to three (3) minutes, and avoid repetitious comments. Thank you.

### 11. Adjournment

The Purpose of the Water/Environmental Committee Meeting, which will immediately follow the Lake/Airport Committee Meeting, is for discussion and consideration in whole or in part of the following subject matters and/or motions to approve/deny/reject/review/table/amend:

1. Monthly Status Report
2. Plocher Change Order #5 Approval

3. Invoices from Benton & Associates, Clark Dietz, Dickinson Hussman
  4. Water Main Extension Sunset Blvd.
  5. Water Collection Office Update
  6. Water Superintendent Updates
  7. Water Superintendent Salary Adjustment
  8. Any Other Matters Which May Properly Come Before This Committee
- Per subparagraph (g) of 5 ILCS 120/2.06, this portion of the Water/Environmental Committee Meeting is reserved for any person wishing to address the Committee on any relevant subject matters concerning the City. The Illinois Open Meetings Act (5 ILCS 120/1 et seq.) mandates NO action shall be taken on subject matters not listed on the agenda, but the Committee may direct staff to address the topic or refer the subject matter to a future Council and/or Committee Meeting. If anyone wishes to address the Committee, please provide your name and address, limit your comments or presentation to three (3) minutes, and avoid repetitious comments. Thank you.

9. Adjournment

Your attendance will be appreciated.

Ernie Dorchinecz, Chairman  
Lake/Airport Committee

Shawn Burtle, Chairman  
Water/Environmental Committee

ED/SB: ss

cc: Mayor Barry  
City Attorney  
All Other Aldermen  
Jacque Nation  
Bill Newberry  
Bart Bialas  
David Speagle  
All Other Superintendents  
Joe Greene  
Kellie Hamell

Breeze Courier  
State Journal Register  
WCFN  
WTIM  
Herald & Review  
WAND  
Chamber of Commerce  
Nick Hackney  
Benton & Associates  
Alan Mills  
Bill Jones  
Brandis Aircraft  
Dave Copenbarger  
Rod and Lisa Sheedy  
Chrissy Tellor  
Larry Vaughn

# CITY OF TAYLORVILLE



OFFICE OF THE CITY CLERK  
115 North Main Street  
Taylorville, Illinois 62568  
Phone (217) 824-2101  
cityclerk@taylorville.net

## NOTICE

This Meeting will be held with respect to the "Social Distancing Guidelines"; and will be conducted remotely, in whole or in part, by video and/or audio conferencing and recording and/or by teleconference.

Because of the Governor's "stay at home" Order, members of the general public (except for City officials, officers, and employees and members of the press) are prohibited from attending this meeting in person.

However, any person who wishes to address the Water/Environmental Committee, Lake/Airport Committee during this meeting may send an email during this meeting to the Mayor at [mayorbarry@taylorville.net](mailto:mayorbarry@taylorville.net). If timely received, your email will be addressed during the subparagraph (g) of 5 ILCS 120/2.06 "general Comments" portion of the Agenda.

May 8, 2020

## AGENDA

TO: Members of the Water/Environmental Committee, Lake/Airport Committee

Water Committee  
Ernie Dorchinecz  
Larry Budd  
Chris Skultety

Lake /Airport Committee  
Shawn Burtle  
Larry Budd  
Chris Skultety

There will be a meeting of the Water/Environmental Committee and Lake/Airport Committee on Thursday, May 14, 2020 at 6:00 P.M. in the Council Chambers of the Municipal Building, 115 North Main, Taylorville, Illinois.

The purpose of the Water/Environmental Committee Meeting, which begins at 6:00 P.M., is for discussion and consideration in whole or in part of the following subject matters and/or motions to approve/deny/reject/review/table/amend:

1. Monthly Status Report
2. Plocher Invoice
3. Invoice from Benton & Associates, Clark Dietz & Dickinson Hussman
4. Award Service Line Material Bids
5. Amend Fire Hydrant Rental Policy
6. Water Collection Office Update
7. Water Superintendent's Report
8. Any Other Matters Which May Properly Come Before This Committee

Per Public Act 96-1473 this portion of the Water/Environmental Committee Meeting is reserved for any person wishing to address the Committee on issues that are relevant to that Committee. The Illinois Open Meetings Act (5 ILCS 120/1) mandates NO action shall be taken on matters not listed on this agenda, but the Committee may direct staff to address the topic or refer the matter to a future Water/Environmental Committee Meeting or a different Committee. Please provide the Committee with your name & address; try to limit presentation to three (3) minutes; and avoid repetitious comments. Thank you.

#### 9. Adjournment

The purpose of the Lake/Airport Committee Meeting, which will immediately follow the Water/Environmental Committee Meeting is for discussion and consideration in whole or in part of the following subject matters and/or motions to approve/deny/reject/review/table/amend:

1. Airport Manager's Report
2. Boat Dock Request
3. Lake Lot Lease Addendum
4. Lake Superintendents Report
5. Any Other Matters Which May Properly Come Before This Committee

Per Public Act 96-1473 this portion of the Lake/Airport Committee Meeting is reserved for any person wishing to address the Committee on issues that are relevant to that Committee. The Illinois Open Meetings Act (5 ILCS 120/1) mandates NO action shall be taken on matters not listed on this agenda, but the Committee may direct staff to address the topic or refer the matter to a future Lake/Airport Committee Meeting or a different Committee. Please provide the Committee with your name & address; try to limit presentation to three (3) minutes; and avoid repetitious comments. Thank you.

#### 6. Adjournment

Your attendance will be appreciated.

Shawn Burtle, Chairman  
Water/ Environmental Committee

Ernie Dorchinecz, Chairman  
Lake/Airport Committee

SB/ED: ss

cc: Mayor Barry  
City Attorney  
All Other Aldermen  
City Treasurer  
David Speagle  
Bart Bialas  
All Other Superintendents  
Bill Newberry  
Benton & Associates  
Kellie Hamell

Breeze Courier  
State Journal Register  
WCFN  
WTIM  
Herald & Review  
WAND  
Chamber of Commerce  
Nick Hackney  
Alan Mills  
Bill Jones  
Brandis Aircraft  
Mark Ostermeier



# TAYLORVILLE AIRPORT

1501 South Spresser Taylorville, IL 62568 Tele. (217) 824-9313

## Superintendent Airport Report

May 14, 2020

### New Credit Card Reader

I'm coordinating the installation of the M4000. Weather permitting, installation will be in May. Waiting for better weather to install new credit card reader.

### Airport Block Grant

Taylorville Airport has qualified for a \$30,000 100% grant. I'm working on lining up apps and Agreements. Treasurer Nation is working on the ICQ (Internal Control Questionnaire) for fiscal year 2021. This grant can be spent on wages, insurance, Maintenance, Supplies almost anything.

### Economic Impact Study

IDA is conducting an economic impact study. The last one was done in 2011. I'm to receive forms and questionnaires. Meeting with them on 5-26-20.

### Taxiway Maintenance Project

The first phase of the 1.5 million maintenance rehabbing of the taxiway (south half), new LED lighting, installing a new rotating beacon on city property, and our cost approximately is \$70,000. I'm in the process of talking to IDA about getting our local cost lowered to \$15,000 to \$30,000.

### Solar Energy Production

The month of **March & April** produced **4250.1 KWH**. This is approximately **\$637.67** in electricity cost savings to the city. To date the solar panels has produced **198,721.1 KWH** of electricity. This has save the City approximately **\$29,808.16** in electricity cost.

### What has happen at the Airport?

- Regulator/Transformer for the East/West runway is over loading.
- Replaced battery in courtesy car on 2-13-20
- Security light was replaced with a LED light on 2-17-20
- 8200 gallons of Avgas was delivered on 3-6-20
- Waiting for north and south hangar roof estimates
- Waiting for runway re-stripping estimates
- Purchased 7500 gallons of Jet -A on 4-6-20

### March & April Fuel Sales

Avgas -	3365 Gals
Jet A -	3438 Gals
<b>Total</b>	<b>6803 Gals.</b>

Adding micros to the Envoy remotely is possible in Enlighten. Click here to find out more. [x](#)



Enlighten

Installed by StraightUp Solar  
May 2012

## Monthly Energy Production Report

Taylorville Airport

Taylorville, IL

This report provides energy production for April.

Generated for William Newberry  
on 05/01/2020

**Address**  
11696 Lilburn Park Road  
St. Louis, MO 63146  
United States

Customer Support Email  
support@straightupsolar.com

Customer Support Phone  
314-218-2663

Website URL  
www.straightupsolar.com

Week	Peak Power	Energy Produced
04/01/2020 - 04/07/2020	15,713 W	512.1 kWh
04/08/2020 - 04/14/2020	17,454 W	676.6 kWh
04/15/2020 - 04/21/2020	17,564 W	622.8 kWh
04/22/2020 - 04/28/2020	16,789 W	583.2 kWh
04/29/2020 - 04/30/2020	17,207 W	175.6 kWh
April 2020 Total:		2,570.3 kWh
Previous Month Total:		1,679.8 kWh
Year to Date:		6,189.7 kWh
Lifetime Production:		198,390.5 kWh

## Your Carbon Offset for this month: 3,920.0 lbs

You have offset the equivalent of: **46 Trees**



# Monthly Energy Production Report

Taylorville Airport

Taylorville, IL

This report provides energy production for March.

Generated for William Newberry  
on 05/01/2020

**Address**

11696 Lilburn Park Road  
St. Louis, MO 63146  
United States

Customer Support Email  
support@straightupsolar.com

Customer Support Phone  
314-218-2663

Website URL  
www.straightupsolar.com

Week	Peak Power	Energy Produced
03/01/2020 - 03/07/2020	15,515 W	636.5 kWh
03/08/2020 - 03/14/2020	14,641 W	264.8 kWh
03/15/2020 - 03/21/2020	15,412 W	271.3 kWh
03/22/2020 - 03/28/2020	15,462 W	235.6 kWh
03/29/2020 - 03/31/2020	16,318 W	271.6 kWh
March 2020 Total:		1,679.8 kWh
Previous Month Total:		1,120.8 kWh
Year to Date:		3,619.4 kWh
Lifetime Production:		198,390.5 kWh

## Your Carbon Offset for this month: 2,560.0 lbs

You have offset the equivalent of: **30 Trees**



# TAYLORVILLE AIRPORT FUEL TOTALS

YEAR	JAN.	FEB.	MAR.	APRIL	MAY	JUNE	JULY	AUG.	SEPT.	OCT.	NOV.	DEC.	PER GAL. TOTALS	
2013 - JET	1068	250	1464	319	640	1588	1685	1393	1228	1654	1074	515	12,878	TOTAL
2013 - LOW	1069	813	1364	1956	2373	2809	3990	3151	2848	461	1582	933	23,349	36227
2014 - JET	1520	0	2049	508	1110	1297	1118	980	704	1114	619	706	11,725	TOTAL
2014 - LOW	829	758	2110	2790	3029	2111	2627	2449	2849	1650	1047	952	23,201	34926
2015 - Jet	930	1187	851	861	1387	450	1512	1779	1620	772	781	252	12,383	TOTAL
2015 - LOW	609	528	1387	1604	1338	3119	2740	2124	1983	1623	1387	945	19,387	31770
2016 - JET	1463	702	2186	1221	1041	1595	914	2712	1844	2202	2043	1897	19,820	TOTAL
2016 - LOW	443	1138	1470	1965	3270	2248	2412	1521	1611	1386	1953	895	20,312	40132
2017 - JET	1437	2597	1260	2644	1395	1023	3321	4534	2105	4136	1712	782	26,946	TOTAL
2017 - LOW	495	990	989	1393	2930	3219	3935	2620	2137	1735	950	503	21,896	48,842
2018 - Jet	739	159	1554	1982	1045	1683	2911	3498	1830	3651	1307	968	21,327	TOTAL
2018 - Low	669	593	971	1410	1660	2855	4329	2289	2345	1408	865	984	20,348	41,675
2019 - Jet	557	1457	1108	2165	808	1334	851	3523	940	2084	495	1483.9	16,806	TOTAL
2019 - Low	412	463	1173	2246	1876	2036	3453	2551	2172	1677	1406	1641.71	21,107	37,913
2020 - Jet	479	1383	1687	2055									5,604	TOTAL
2020 - Low	1037	1261	1681	2104									6,083	11,687
<b>TOTAL</b>	<b>18,927</b>	<b>21,438</b>	<b>33,171</b>	<b>37,250</b>	<b>37,056</b>	<b>38,994</b>	<b>49,324</b>	<b>46,693</b>	<b>36,322</b>	<b>36,572</b>	<b>24,172</b>	<b>18,126</b>	<b>312,654</b>	

THE CITY OF TAYLORVILLE  
APPLICATION FOR ANY BUILDING STRUCTURE OR IMPROVEMENT ON OR WITHIN  
LAKE TAYLORVILLE ON PRIVATE PROPERTY

PROPERTY ADDRESS: 2505 Eastwood Drive Taylorville, IL 62568

DESCRIPTION: Boat dock

CONTRACTOR: B&R Construction

PLEASE ATTACH A COPY OF THE GENERAL LIABILITY CERTIFICATE OF INSURANCE IN THE AMOUNT OF \$1,000,000.00 (ONE MILLION DOLLARS) AND BE SURE THAT THE CERTIFICATE NAMES THE "CITY OF TAYLORVILLE, ILLINOIS, A MUNICIPAL CORPORATION, AND ITS ELECTED AND/OR APPOINTED MAYOR, CITY COUNCIL, OFFICIALS, OFFICERS, EMPLOYEES, AND AGENTS." AS AN ADDITIONAL INSURED

PLEASE ATTACH A DRAWING/BUILDING PLAN WITH DIMENSION

ALL DOCUMENTATION SHOULD BE SUBMITTED TO THE CITY CLERK'S OFFICE APPROVAL WILL BE GRANTED BY THE LAKE COMMITTEE AND CITY COUNCIL

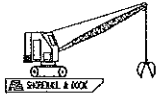
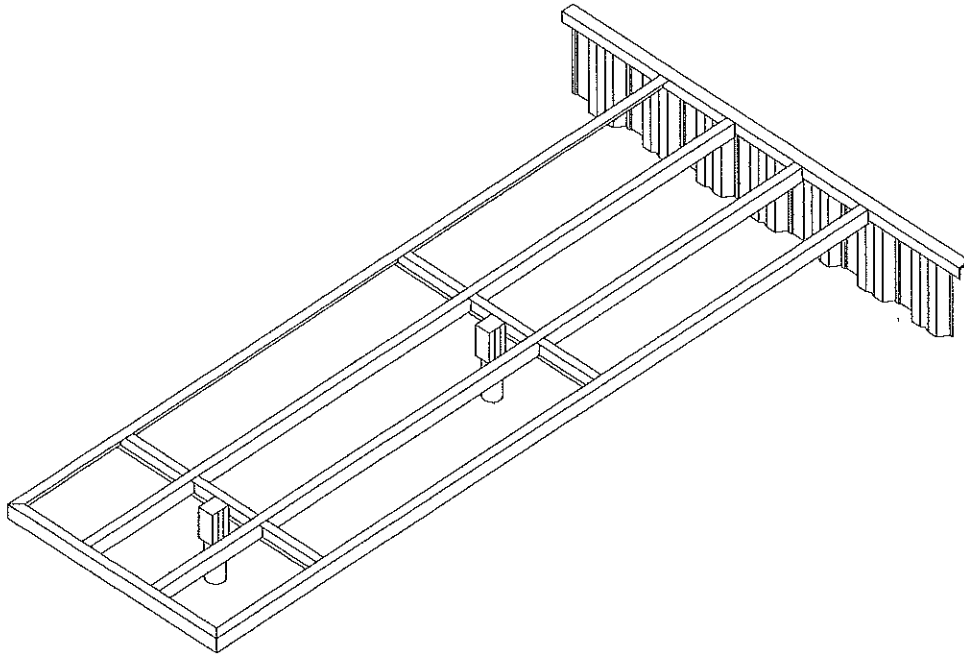

**B&R Construction 1315 E. Park Street Taylorville, IL 62568**

**(800) 462-3625**

AMOUNT	DESCRIPTION	PRICE
	<p style="text-align: center;"><b>STEEL FRAMEWORK FOR 6' x 34' PIER</b>  <b>RE: PRINT #ISO6 &amp; #SLP6</b></p> <p>The side of the boat house closest to the shore will be supported by steel sheet piles that are not priced on this page of the bid. (See bid for steel shorwall.) The posts are approximately 6" inside diameter, used, well casing. They are driven to the maximum depth possible with a 2000 lb. drop hammer, cut to the proper height, then filled with reinforcing rods and sacrete.</p> <p>The pier is constructed of 6x8.2 C-channel and is attached to the posts with 4" I-Beam. The pier is constructed in such a manner so that nailers can be attached to the steel and decking boards can be nailed to the nailers without the need for a floor joist system.</p> <p>This price includes all material, labor &amp; sales tax. Price does not include any woodwork, shorwall, or the removal of any existing structure.</p>	<p>\$ 8,660.00</p>
	<p>Total list price</p>	<p>\$ 8,660.00</p>

August 7, 2020

## AGENDA

TO: Members of the Lake/Airport Committee and the Water/Environmental Committee

Lake/Airport Committee

Shawn Burtle

Larry Budd

Chris Skultety

Water/Environmental Committee

Ernie Dorchinecz

Larry Budd

Chris Skultety

There will be a meeting of the Lake/Airport Committee and the Water/Environmental Committee on Thursday, August 13, 2020 starting at 6:00 P.M. in the Council Chambers of the Municipal Building, 115 North Main, Taylorville, Illinois.

The Purpose of the Lake/Airport Committee Meeting, which begins at 6:00 P. M., is for discussion and consideration in whole or in part of the following subject matters and/or motions to approve/deny/reject/review/table/amend:

1. Privatization of Lake Marina
  2. Lake Lot/Campground Process
  3. Duck Blind and Deer Drawing
  4. Revenue for Dredging of Lake Taylorville
  5. Location of Tent Camping
  6. Service Connect Procedure
  7. Lake Superintendent's Report
  8. Airport Runway
  9. Airport Report
  10. Any Other Matters Which May Properly Come Before This Committee
- Per subparagraph (g) of 5 ILCS 120/2.06, this portion of the Lake/Airport Committee Meeting is reserved for any person wishing to address the Committee on any relevant subject matters concerning the City. The Illinois Open Meetings Act (5 ILCS 120/1 et seq.) mandates NO action shall be taken on subject matters not listed on the agenda, but the Committee may direct staff to address the topic or refer the subject matter to a future Council and/or Committee Meeting. If anyone wishes to address the Committee, please provide your name and address, limit your comments or presentation to three (3) minutes, and avoid repetitious comments. Thank you.
11. Adjournment

The Purpose of the Water/Environmental Committee Meeting, which will immediately follow the Lake/Airport Committee Meeting, is for discussion and consideration in whole or in part of the following subject matters and/or motions to approve/deny/reject/review/table/amend:

1. Monthly Status Report
  2. Plocher Construction Invoice
  3. Invoices from Benton & Associates, Clark-Dietz & Dickinson Hussman
  4. Purchase 2 Carbon Feed Pumps
  5. Approve Hach Maintenance Agreement
  6. Purchase Knox Box for Water Plant
  7. Water Collection Office Update
  8. Water Superintendent Updates
  9. Any Other Matters Which May Properly Come Before This Committee
- Per subparagraph (g) of 5 ILCS 120/2.06, this portion of the Water/Environmental Committee Meeting is reserved for any person wishing to address the Committee on any relevant subject matters concerning the City. The Illinois Open Meetings Act (5 ILCS 120/1 et seq.) mandates NO action shall be taken on subject matters not listed on the agenda, but the Committee may direct staff to address the topic or refer the subject matter to a future Council and/or Committee Meeting. If anyone wishes to address the Committee, please provide your name and address, limit your comments or presentation to three (3) minutes, and avoid repetitious comments. Thank you.

10. Adjournment

Your attendance will be appreciated.

Ernie Dorchinecz, Chairman  
Lake/Airport Committee

Shawn Burtle, Chairman  
Water/Environmental Committee

ED/SB: ss

cc: Mayor Barry  
City Attorney  
All Other Aldermen  
Jacque Nation  
Geoffrey Ortman  
David Speagle  
All Other Superintendents  
Benton & Associates  
Kellie Hamell  
Andy Goodall

Breeze Courier  
State Journal Register  
WCFN  
WTIM  
Herald & Review  
WAND  
Chamber of Commerce  
Nick Hackney  
Bill Jones  
Alan Mills  
Matt Whalen  
Josh Assad  
Chris Biondolino



September 4, 2020

## AGENDA

TO: Members of the Water/Environmental Committee, Lake/Airport Committee

Water Committee

Ernie Dorchinecz  
Larry Budd  
Chris Skultety

Lake /Airport Committee

Shawn Burtle  
Larry Budd  
Chris Skultety

There will be a meeting of the Water/Environmental Committee and Lake/Airport Committee on Thursday, September 10, 2020 at 6:00 P.M. in the Council Chambers of the Municipal Building, 115 North Main, Taylorville, Illinois.

The purpose of the Water/Environmental Committee Meeting, which begins at 6:00 P.M., is for discussion and consideration in whole or in part of the following subject matters and/or motions to approve/deny/reject/review/table/amend:

1. Monthly Status Report
2. Plocher Invoice and Documents
3. Invoice from Benton & Associates, Clark Dietz & Dickinson Hussman
4. Award Hydrant Bids
5. Award Valve Box Quotes
6. Direct City Attorney to Draft Tower Antenna Agreement with CTI
7. Water Collection Office Update
8. Water Superintendent's Report
9. Any Other Matters Which May Properly Come Before This Committee

Per Public Act 96-1473 this portion of the Water/Environmental Committee Meeting is reserved for any person wishing to address the Committee on issues that are relevant to that Committee. The Illinois Open Meetings Act (5 ILCS 120/1) mandates NO action shall be taken on matters not listed on this agenda, but the Committee may direct staff to address the topic or refer the matter to a future Water/Environmental Committee Meeting or a different Committee. Please provide the Committee with your name & address; try to limit presentation to three (3) minutes; and avoid repetitious comments. Thank you.

10. Adjournment

The purpose of the Lake/Airport Committee Meeting, which will immediately follow the Water/Environmental Committee Meeting is for discussion and consideration in whole or in part of the following subject matters and/or motions to approve/deny/reject/review/table/amend:

1. Airport Farm Lease-Nation Farms
2. Airport Report
3. Two Campers on Campgrounds
4. Discussion Only-Lists for Lake Lots, Campgrounds and Boats
5. Privatizing of Lake Marina
6. Portable Credit Card Reader
7. Scanner for the Ruby Cash Register System
8. Revenue for Dredging of Lake
9. Lake Superintendents Report
10. Any Other Matters Which May Properly Come Before This Committee

Per Public Act 96-1473 this portion of the Lake/Airport Committee Meeting is reserved for any person wishing to address the Committee on issues that are relevant to that Committee. The Illinois Open Meetings Act (5 ILCS 120/1) mandates NO action shall be taken on matters not listed on this agenda, but the Committee may direct staff to address the topic or refer the matter to a future Lake/Airport Committee Meeting or a different Committee. Please provide the Committee with your name & address; try to limit presentation to three (3) minutes; and avoid repetitious comments. Thank you.

11. Adjournment

Your attendance will be appreciated.

Shawn Burtle, Chairman  
Water/ Environmental Committee

Ernie Dorchinecz, Chairman  
Lake/Airport Committee

SB/ED: ss

cc: Mayor Barry  
City Attorney  
All Other Aldermen  
City Treasurer  
David Speagle  
Geoffrey Ortman  
All Other Superintendents  
Andy Goodall  
Benton & Associates  
Kellie Hamell

Breeze Courier  
State Journal Register  
WCFN  
WTIM  
Herald & Review  
WAND  
Chamber of Commerce  
Nick Hackney  
Alan Mills  
Bill Jones  
Brandis Aircraft  
Bruce Nation

October 2, 2020

## AGENDA

TO: Members of the Lake/Airport Committee and the Water/Environmental Committee

Lake/Airport Committee

Shawn Burtle  
Larry Budd  
Chris Skultety

Water/Environmental Committee

Ernie Dorchinecz  
Larry Budd  
Chris Skultety

There will be a meeting of the Lake/Airport Committee and the Water/Environmental Committee on Thursday, October 8, 2020 starting at 6:00 P.M. in the Council Chambers of the Municipal Building, 115 North Main, Taylorville, Illinois.

The Purpose of the Lake/Airport Committee Meeting, which begins at 6:00 P. M., is for discussion and consideration in whole or in part of the following subject matters and/or motions to approve/deny/reject/review/table/amend:

1. Lists for Lake Lots, Camp Grounds and Boat Docks
  2. Update for Portable Card Reader
  3. Update for Scanner for the Ruby Register System
  4. Revenue for Dredging of Lake Taylorville
  5. Metal Replacement Signs at the Marina
  6. Remove Trailer Parking Signs at Marina
  7. Tent Only Parking Signs
  8. Lake Superintendent's Report
  9. Airport Report
  10. Any Other Matters Which May Properly Come Before This Committee
- Per subparagraph (g) of 5 ILCS 120/2.06, this portion of the Lake/Airport Committee Meeting is reserved for any person wishing to address the Committee on any relevant subject matters concerning the City. The Illinois Open Meetings Act (5 ILCS 120/1 et seq.) mandates NO action shall be taken on subject matters not listed on the agenda, but the Committee may direct staff to address the topic or refer the subject matter to a future Council and/or Committee Meeting. If anyone wishes to address the Committee, please provide your name and address, limit your comments or presentation to three (3) minutes, and avoid repetitious comments. Thank you.
11. Adjournment

The Purpose of the Water/Environmental Committee Meeting, which will immediately follow the Lake/Airport Committee Meeting, is for discussion and consideration in whole or in part of the following subject matters and/or motions to approve/deny/reject/review/table/amend:

1. Monthly Status Report
  2. Approve Tower Antenna Agreement with CTI
  3. Water Collection Office Update
  4. Water Superintendent Updates
  5. Any Other Matters Which May Properly Come Before This Committee
- Per subparagraph (g) of 5 ILCS 120/2.06, this portion of the Water/Environmental Committee Meeting is reserved for any person wishing to address the Committee on any relevant subject matters concerning the City. The Illinois Open Meetings Act (5 ILCS 120/1 et seq.) mandates NO action shall be taken on subject matters not listed on the agenda, but the Committee may direct staff to address the topic or refer the subject matter to a future Council and/or Committee Meeting. If anyone wishes to address the Committee, please provide your name and address, limit your comments or presentation to three (3) minutes, and avoid repetitious comments. Thank you.

6. Adjournment

Your attendance will be appreciated.

Ernie Dorchinecz, Chairman  
Lake/Airport Committee

Shawn Burtle, Chairman  
Water/Environmental Committee

ED/SB: ss

cc: Mayor Barry  
City Attorney  
All Other Aldermen  
Jacque Nation  
Geoffrey Ortman  
David Speagle  
All Other Superintendents  
Benton & Associates  
Kellie Hamell  
Andy Goodall

Breeze Courier  
State Journal Register  
WCFN  
WTIM  
Herald & Review  
WAND  
Chamber of Commerce  
Nick Hackney  
Bill Jones  
Alan Mills  
Matt Whalen

# CITY OF TAYLORVILLE



OFFICE OF THE CITY CLERK  
115 North Main Street  
Taylorville, Illinois 62568  
Phone (217) 824-2101  
cityclerk@taylorville.net

December 4, 2020

## AGENDA

TO: Members of the Lake/Airport Committee

### Lake/Airport Committee

Shawn Burtle  
Larry Budd  
Chris Skultety

There will be a meeting of the Lake/Airport Committee on Thursday, December 10, 2020 starting at 6:00 P.M. in the Council Chambers of the Municipal Building, 115 North Main, Taylorville, Illinois.

The Purpose of the Lake/Airport Committee Meeting, which begins at 6:00 P. M., is for discussion and consideration in whole or in part of the following subject matters and/or motions to approve/deny/reject/review/table/amend:

1. Hangar Roof Repairs
  2. Airport Report
  3. Marina Improvements
  4. Changes to the Lake Lot and Campground Lease
  5. Campground Rent Payment Procedures
  6. Subletting of Lake Property
  7. Police Powers
  8. Lottery Procedures
  9. Marina Card Reader Update
  10. Storage Sheds
  11. Revenue for Dredging of Lake Taylorville
  12. Lake Superintendent's Report
  13. Any Other Matters Which May Properly Come Before This Committee
- Per subparagraph (g) of 5 ILCS 120/2.06, this portion of the Lake/Airport Committee Meeting is reserved for any person wishing to address the Committee on any relevant subject matters concerning the City. The Illinois Open Meetings Act (5 ILCS 120/1 et seq.) mandates NO action shall be taken on subject matters not listed on the agenda, but the Committee may direct staff to address the topic or refer the subject matter to a future Council and/or Committee Meeting. If anyone wishes to address the Committee, please provide your name and address, limit your comments or presentation to three (3) minutes, and avoid repetitious comments. Thank you.
14. Adjournment

Your attendance will be appreciated.

Ernie Dorchinecz, Chairman  
Lake/Airport Committee

ED: ss

cc: Mayor Barry  
City Attorney  
All Other Aldermen  
Jacque Nation  
Geoffrey Ortman  
David Speagle  
All Other Superintendents  
Benton & Associates  
Kellie Hamell  
Andy Goodall

Breeze Courier  
State Journal Register  
WCFN  
WTIM  
Herald & Review  
WAND  
Chamber of Commerce  
Nick Hackney  
Bill Jones  
Christian Nelson  
Matt Whalen